

# Special Encoders & Sensors

Contact encoder, surface mount housing

Impulse ratio 1 rev. = 15 impulses up to 5 rev. = 1 impulse

G 080

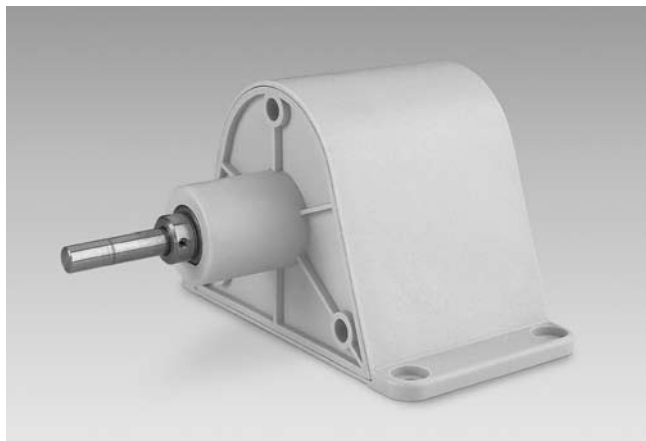

G 080 surface mount housing

## Features

- Encoder with mechanical contact
- As trigger for electromechanical counters
- Impulse voltage 12...230 VAC/VDC
- Surface mount housing (for measuring wheel)
- Ratio up to one revolution = 15 impulses
- Reduction ratio up to 5 revolutions = 1 impulse
- High switching capacity
- Sturdy design

## Technical data - electrical ratings

Voltage supply	12...220 V
Resolution (steps/turn)	0.2...15
Operating mode	Pulse emission in both rotational directions
Contact load	≤30 W (100 VA) ≤230 V (approx. 2 A)
Sensing method	Mechanic
Output frequency	≤0.025 kHz
Output signals	Contact

## Technical data - mechanical design

Housing	ø73 mm
Shaft	ø7 mm (sinter bronze slide bearing)
Protection DIN EN 60529	IP 52
Operating speed	≤1500 rpm
Starting torque	≤0.02 Nm IP 30
Material	Housing: GFV Polycarbonat
Operating temperature	-10...+60 °C
Relative humidity	95 % non-condensing
Weight approx.	250 g
E-connection	Cable

# Special Encoders & Sensors

Contact encoder, surface mount housing

Impulse ratio 1 rev. = 15 impulses up to 5 rev. = 1 impulse

G 080

## Part number

G 080.0

	<u>Pulse per rotation</u>
10A101	1 rev. = 1 impulse contact cams impulse/interval 1:1
10A202	1 rev. = 2 impulses contact cams of several parts
10A205	1 rev. = 5 impulses contact cams of several parts
20A110	2 rev. = 1 impulse contact cams impulse/interval 1:1
20A113	5 rev. = 1 impulse contact cams impulse/interval 1:1

Supplied with PG9 gland and 0.3 m cable 2 x 1 mm.

G 080 is a mechanically-operated encoder providing a surface mount housing. Mechanical rotary movements are converted into impulses by interrupted contact resulting in the existing circuit opening or closing. Impulse ratios are available within the range of 1 turn = 15 impulses up to max. 32 turns.

## Dimensions

